

NERI



THE NEW LIGHTING IN VIA MAGISTRALE, BENEVENTO.

Strix is the new lamppost designed by the studio of Cannata & Partners Lighting Design and realized by Neri for Benevento.

The designer describes the idea that guided him as follows:

The inspiration came from the territory, from the city of Benevento, from its history and its legends; and it was the most famous legend of all, one that still lives in the collective imagination, that gave us our starting point. STRIX arose from the legend of the witch of Benevento, from her pointed hat and from her broomstick.

LA NUOVA ILLUMINAZIONE DELLA VIA MAGISTRALE A BENEVENTO.

Strix è il nuovo lampione progettato dallo studio Cannata & Partners Lighting Design e realizzato da Neri per Benevento.

Il progettista così racconta l'idea che lo ha guidato: *L'ispirazione è venuta dal territorio, dalla città di Benevento, dalla sua storia e dalle sue leggende; e proprio dalla leggenda più famosa, che ancora oggi continua a vivere nell'immaginario collettivo che siamo partiti. STRIX prende spunto dalla leggenda della strega di Benevento, dal suo cappello e dalla sua scopa.*

These two elements were our principal inspiration: the hat for the hood of the lighting fixture and the broomstick for the base.

Making light does not mean revealing the world, causing darkness and all its mysteries to disappear; on the contrary, it means adding a new qualitative value to reality, maybe one rich in mystery, stronger and more involving. It means adding BEAUTY! That is why Strix was born.

I due elementi sono stati il principio ispiratore: il cappello per la copertura del corpo illuminante e la scopa per la base.

Far luce non vuol dire svelare il mondo, far scomparire il buio e i suoi misteri; al contrario vuol dire aggiungere alla realtà una nuova valenza qualitativa, magari ricca di mistero, più forte ed avvolgente, aggiungere BELLEZZA! Ecco perché nasce Strix.



The hood, in metal, has a conical shape and contains the lighting fixture, which formally disappears from view.

Il cappello, in metallo, si presenta con una forma conica e include al suo interno il corpo illuminante, che scompare formalmente dalla vista.



Cappello

Hood

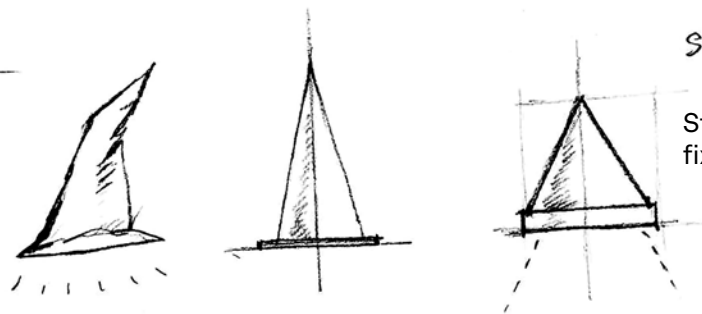

studio del
corpo illuminante

Study for the lighting
fixture

Corpo illuminante Lighting Fixture

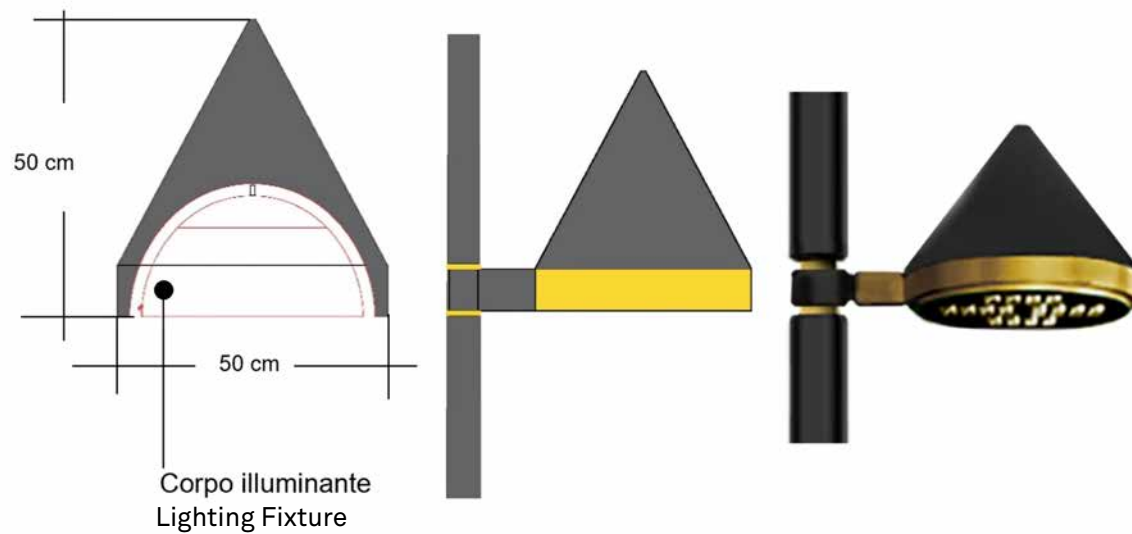

Corpo illuminante
Lighting Fixture



Foto corpo
illuminante
Photo of lighting
fixture

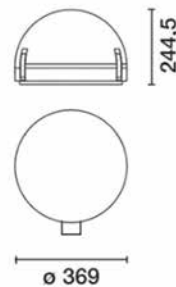





The broomstick has become a base shaped like a cut-off cone with a series of rods in gilded brass decorating it and resembling the bristles of the broom.

La scopa è diventata la base a forma tronco-conica con una serie di aste in ottone dorato che la decorano e richiamano i fili della scopa.

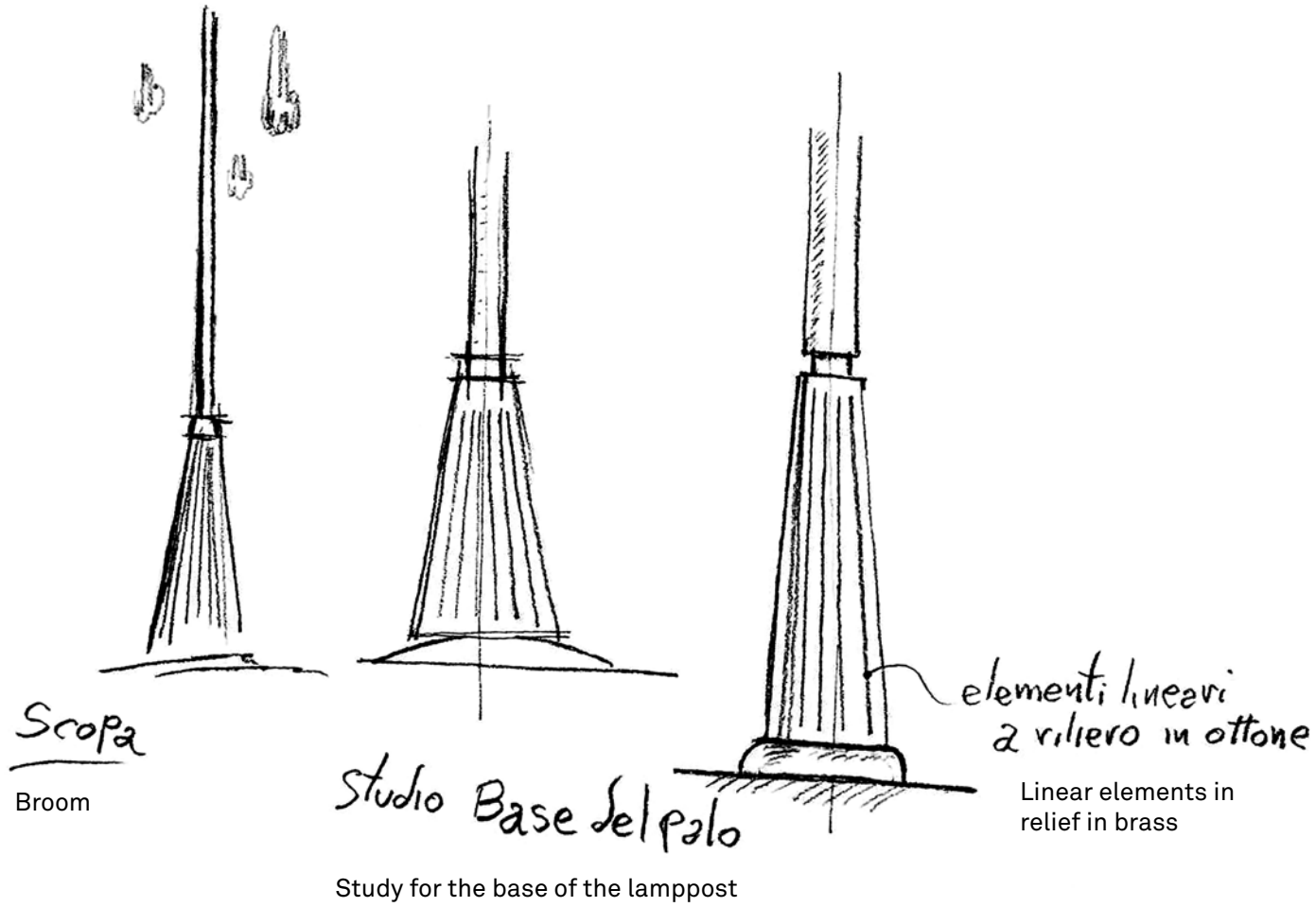

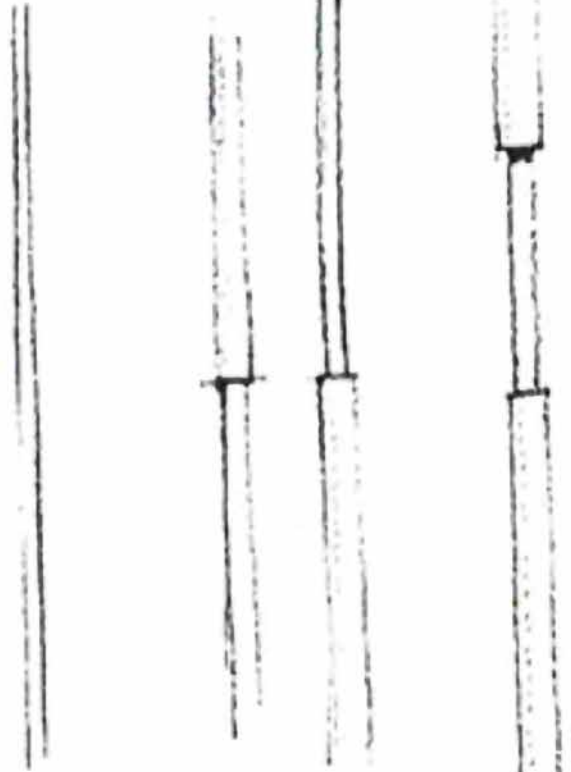

Asta del palo

Pole of the lamppost

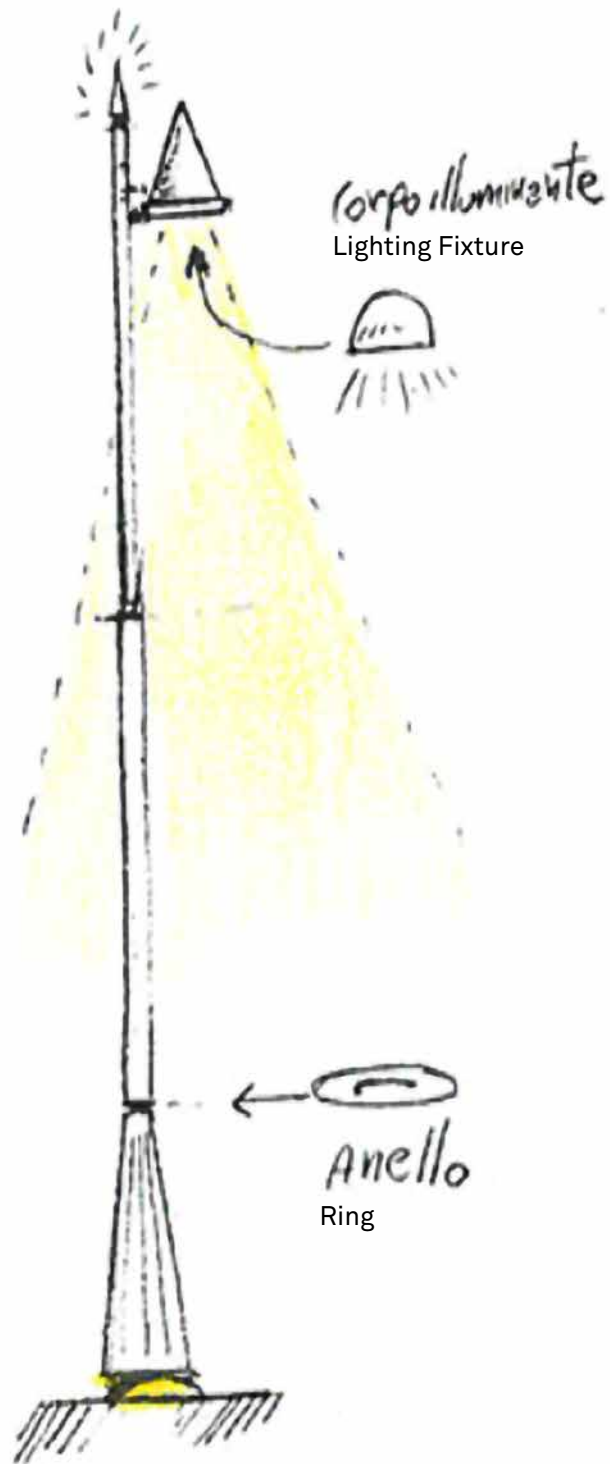

TIPO A h.9mt una lampada

TYPE C one lamp at 9 m

TIPO C h.6mt una lampada

TYPE C one lamp at 6 m







ASSOCIAZIONE
ADP
FEDERAZIONE ITALIANA
DELLA
PIAZZA
SEZIONE PROVINCIALE DI BENEVENTO

ferramenta - elettricità
elettroutensili

arte pizza

PIZZERIA



















The street leading to the famous Arch of Trajan is certainly one of the most important areas of the city. It is interesting to observe the aesthetic evolution of the various lighting fixtures that have succeeded each other over the decades. From the great mushroom-shaped lamppost of the 1960s to the minimalist lamppost with a globe in the 1980s and so to the present-day Strix.

La via che conduce al famoso Arco di Traiano è certamente uno dei luoghi più importanti della città. E' interessante osservare l'evoluzione estetica dei diversi corpi illuminanti che si sono succeduti nei decenni. Dal grande lampione a fungo degli anni 60, al palo minimalista con sfere degli anni 80 fino all'attuale Strix.



Benevento - Via Arco Traiano



Benevento - Via Arco Traiano - Notturno

















CREDITS

Photographs © Antonio Neri, Neri SpA

Project: Cannata & Partners Lighting Design Communication

Installation Company: Artistica Srl

CREDITI

Fotografie © Antonio Neri, Neri SpA

Progetto: Cannata & Partners Lighting Design Communication

Impresa installatrice: Artistica Srl

Thank you
Grazie